

RCS-S6000U WIRING DIAGRAM

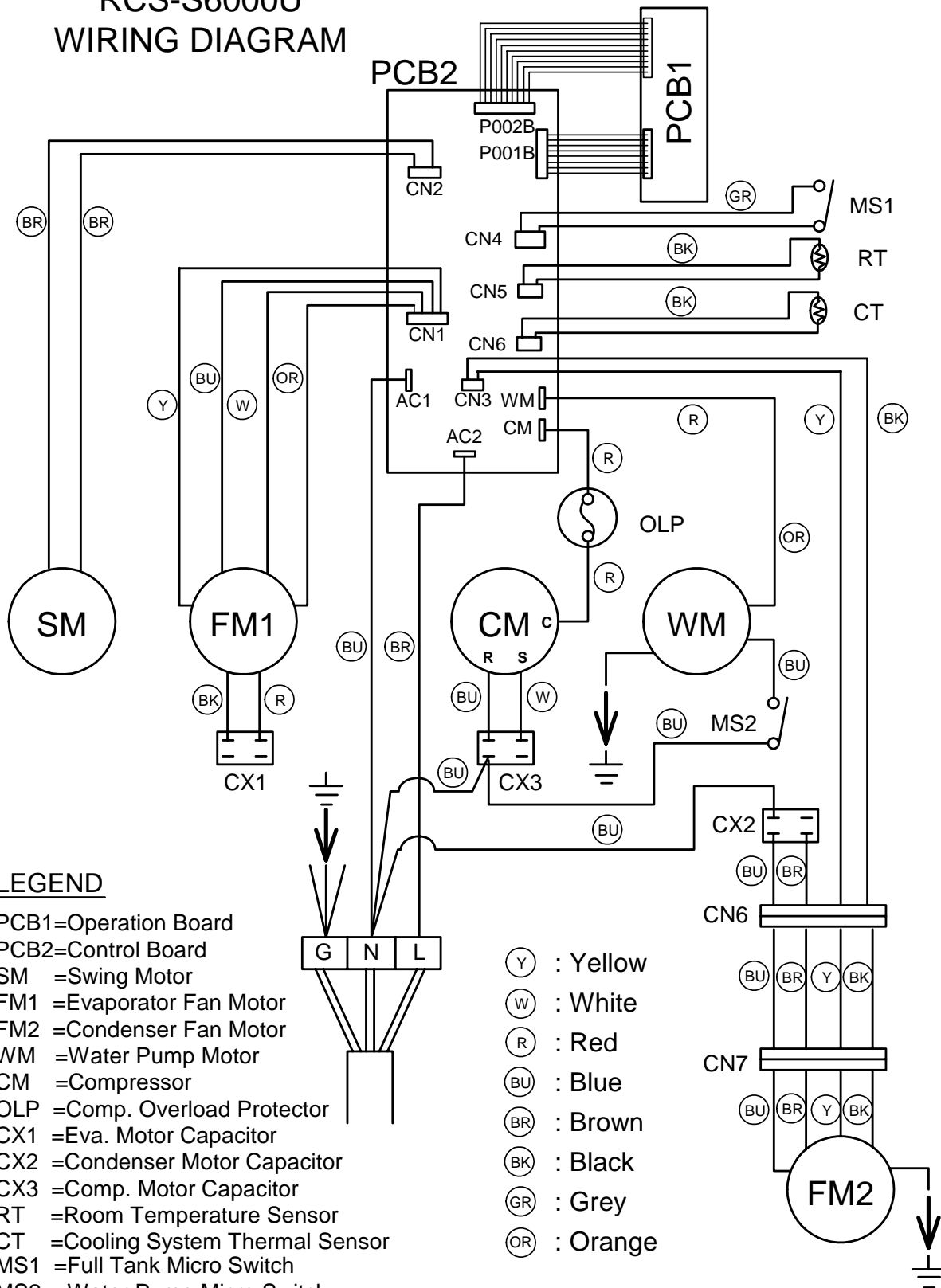

LEGEND

- PCB1=Operation Board
- PCB2=Control Board
- SM =Swing Motor
- FM1 =Evaporator Fan Motor
- FM2 =Condenser Fan Motor
- WM =Water Pump Motor
- CM =Compressor
- OLP =Comp. Overload Protector
- CX1 =Eva. Motor Capacitor
- CX2 =Condenser Motor Capacitor
- CX3 =Comp. Motor Capacitor
- RT =Room Temperature Sensor
- CT =Cooling System Thermal Sensor
- MS1 =Full Tank Micro Switch
- MS2 =Water Pump Micro Switch

- (Y) : Yellow
- (W) : White
- (R) : Red
- (BU) : Blue
- (BR) : Brown
- (BK) : Black
- (GR) : Grey
- (OR) : Orange